

Technical
Drawing

Desenho
Técnico

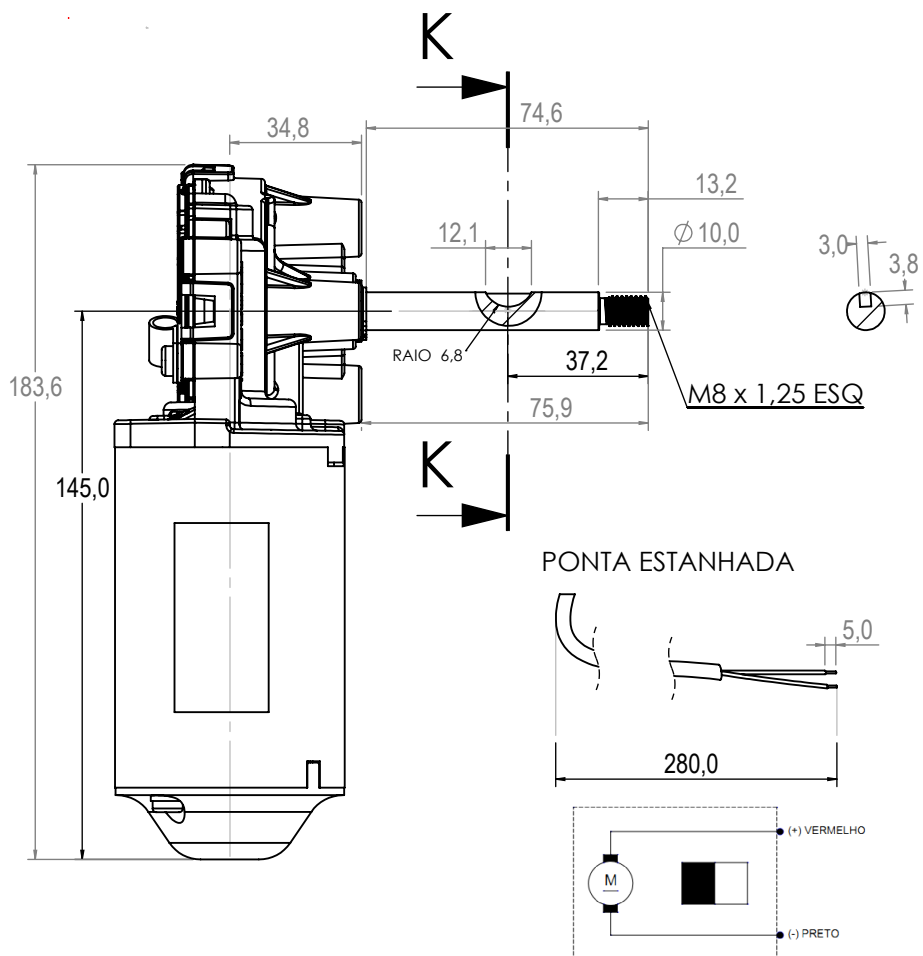
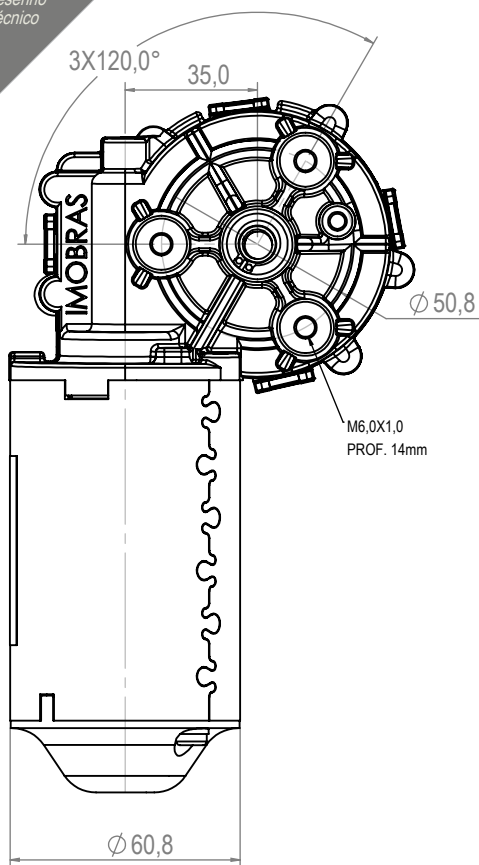

Technical
Specification

Especificação
Técnica

Imagem
Ilustrativa

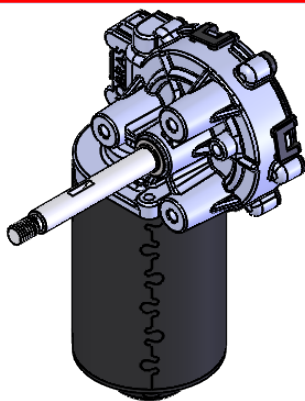

NOTAS:

Aplicação: Industrial

Application: Industrial

100401924

CARACTERÍSTICAS ELÉTRICAS	
U N (V)	27
P N (W)	20
n N (rpm)	33
I N (A)	2,3
I max (A)	12
M N (Nm)	6
M max (Nm)	30
I	63:1
Rotação	L / R
Peso (Kg)	1,500

